

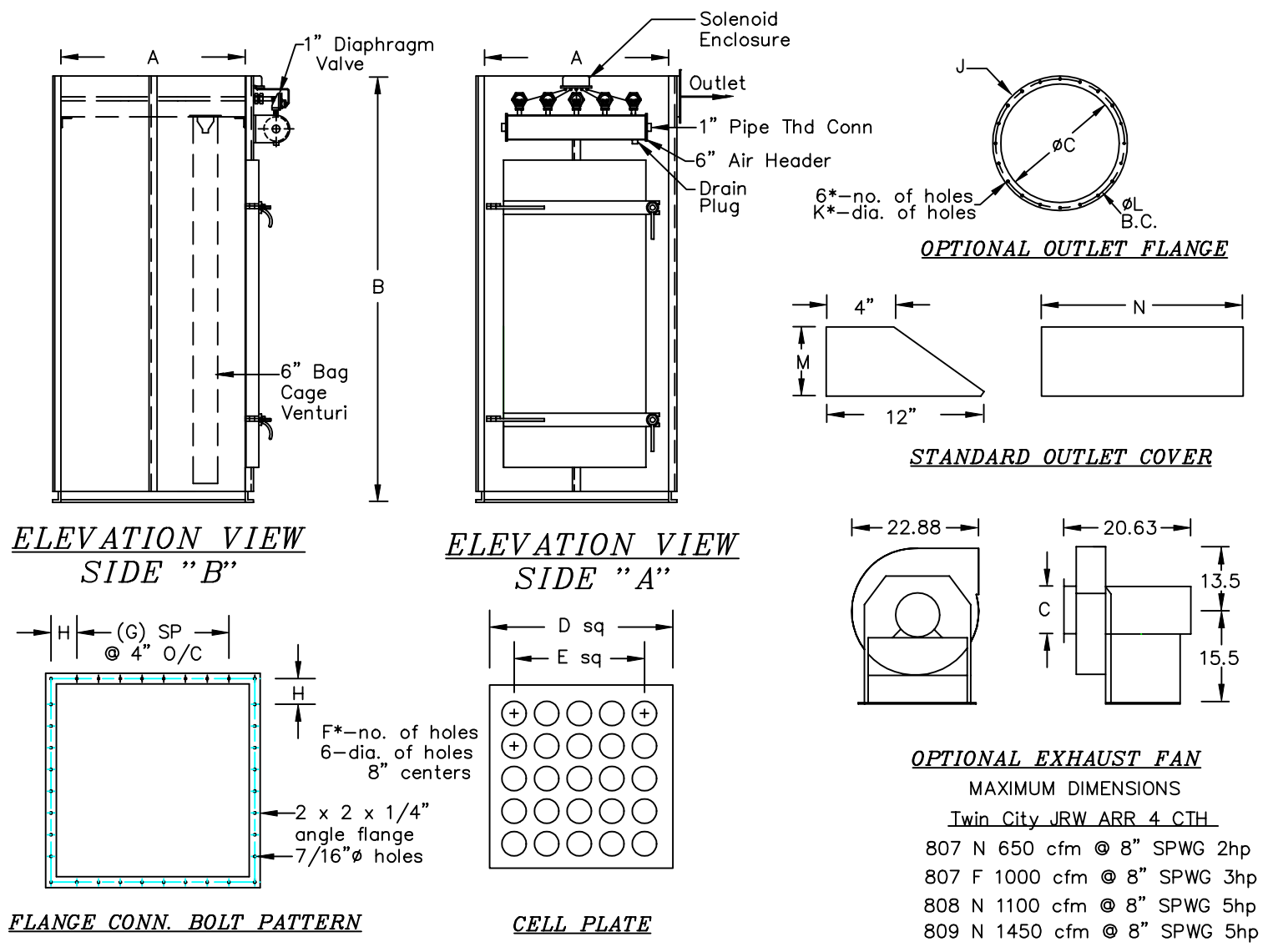

# U. S. Air Filtration, Inc.

*Clearing the Air for a Cleaner Environment*



**OPTIONAL EXHAUST FAN**  
 MAXIMUM DIMENSIONS  
 Twin City JRW ARR 4 CTH  
 807 N 650 cfm @ 8" SPWG 2hp  
 807 F 1000 cfm @ 8" SPWG 3hp  
 808 N 1100 cfm @ 8" SPWG 5hp  
 809 N 1450 cfm @ 8" SPWG 5hp

## Bin Vent Pulse Jet Dust Collector

NOTE: ALL DIMENSIONS ARE LISTED AS DECIMAL INCHES **6" x 7' Bag Side Access**

MODEL	FILTER AREA	A	B	C	D	E	F	G	H	J	K	L	M	N
44-BVPS-84-6	176	36	96	7	36	24	16	8	3	9.38	.38	8.50	7	16
55-BVPS-84-6	275	44	96	8	40	36	25	10	3	10.38	.38	8.50	7	18
66-BVPS-84-6	396	52	96	8	52	40	36	12	3	10.38	.38	9.56	8	20
77-BVPS-84-6	538	60	96	9	60	48	49	14	3	11.63	.44	10.63	9	24

NOTE: ALL DIMENSIONS ARE LISTED AS DECIMAL INCHES **6" x 10' Bag Side Access**

MODEL	FILTER AREA	A	B	C	D	E	F	G	H	J	K	L	M	N
44-BVPS-120-6	251	36	132	7	36	24	16	8	3	9.38	.38	8.50	7	18
55-BVPS-120-6	293	44	132	8	40	36	25	10	3	10.38	.38	8.50	8	20
66-BVPS-120-6	565	52	132	8	52	40	36	12	3	10.38	.44	10.63	9	24
77-BVPS-120-6	769	60	132	9	60	48	49	14	3	11.63	.44	10.63	9	24